

PAPERplus[®] by **STOROpack**



STOROpack

A complete line of paper



Product overview	3
PAPERplus® Classic	4
PAPERplus® Chevron	8
PAPERplus® Shooter	10
Systems integration	12



packaging material

PAPERplus[®] by STOROPack

PAPERplus[®] from Storopack offers a variety of systems that transform paper rolls into packaging material for any application from speedy light-weight filler to strong cushioning pads. Whether you're packing small, medium-sized, large, or heavy industrial items, there is a PAPERplus[®] product that is an efficient and economical solution for your packaging needs.

PAPERplus[®] in-the-box packaging materials are made from recycled and virgin paper. It's durable enough to be used many times and recyclable — making it economical and environmentally friendly.

Efficient. Dependable. Versatile.

- Largest selection of in-the-box paper packaging products and machines in the industry
- Reliable easy-to-operate equipment with efficiencies like programmable keypads and hands-free foot pedal control
- Multiple machine configurations with flexible features and add-on components allow you to fit the equipment to your facility and engineer the most efficient production methods for your packing requirements
- Skilled responsive representatives and service technicians ensure your packaging systems are operating at peak efficiency

Watch for this functionality key

This convenient guide is shown throughout our catalog to help you choose the right PAPERplus[®] product. The functions highlighted on the side of the box ensure you're getting the product that will meet your packaging needs.

Cushion:

Absorbs shock. Protects fragile products.

Block and Brace:

Holds heavy items or single objects in place inside the box.

Void-Fill:

Fills empty space and keeps products from rattling in the box.

Wrap:

Covers product surfaces to avoid contact damage and provides all sides with shock protection.



PAPERplus® Classic

Strong paper pads for reliable protection

Functionality:

- ✓ Cushion
- ✓ Void-Fill
- ✓ Block & Brace
- ✓ Wrap



- Superior all-around protection
- Resists tearing and perforation
- Formed on-demand
- Reuseable and recyclable

PAPERplus® Classic offers the most versatile functionality of any in-the-box paper packaging product. Combining the flexibility of different paper weight options and the use of different packing techniques can make PAPERplus® an economical choice for virtually any application. PAPERplus® pads provide the strength and durability to stabilize heavy objects and the bulk needed for superior cushioning and void-fill.



Cushioning method for fragile items.



Convenient and easy for void-fill applications.



Block and brace objects to prevent migration.



Coil or wrap to stabilize and protect objects.

Choose from two versions of the PAPERplus® Classic machines and a variety of paper ranges that provide paper pads for different packing situations:

■ **PAPERplus® Classic**

Our Classic machine produces hefty paper mattresses that work well in all box sizes.

■ **PAPERplus® GE**

The optimized GE machine produces slightly smaller paper mattresses that work well in all box sizes—especially small to medium boxes. The slightly smaller size lowers in-the-box cost and speeds-up loading and handling.

Both types of paper pads offer the strength and versatility to cushion and protect any item whether it’s heavy, fragile—or just awkward to pack.

Multiple paper choices for unlimited packaging needs

Paper Type	Width x Length	Packaging Volume per roll
GE 1-ply	1066'	95 ft ³
GE 2-ply	918'	125 ft ³
1-ply 40#	29.5" x 1,350' and 1,800'	75-100 ft ³
1-ply 60#	29.5" x 900' and 1,350'	115-170 ft ³
2-ply 30/30#	29.5" x 900' and 1,350'	110-155 ft ³
2-ply 30/50#	29.5" x 900' and 1,350'	125-170 ft ³
2-ply 43/43#	29.5" x 900' and 1,300'	135-185 ft ³
2-ply 50/50#	29.5" x 900' and 1,200'	150-195 ft ³
3-ply 30/30/30#	29.5" x 450'	80 ft ³
3-ply 30/50/30#	29.5" x 900'	175 ft ³



A standard Classic paper roll and the smaller GE paper roll.



PAPERplus® Classic machines use a very effective patented crimping technique to produce paper mattress pads that are reinforced to offer enhanced compression strength over competitive products. This gives you a better cubic volume yield from the paper roll and more reliable protection.

Classic Vertical

Boasting the smallest footprint of the Classic Line, the popular vertical model is ideal for environments where space and speed are important concerns.

Size:	70" H x 36" W x 36" D
Weight:	400 lbs
Power:	110 v
Speed:	Standard – 42 fpm High speed – 120 fpm
Paper:	Single- or double-ply

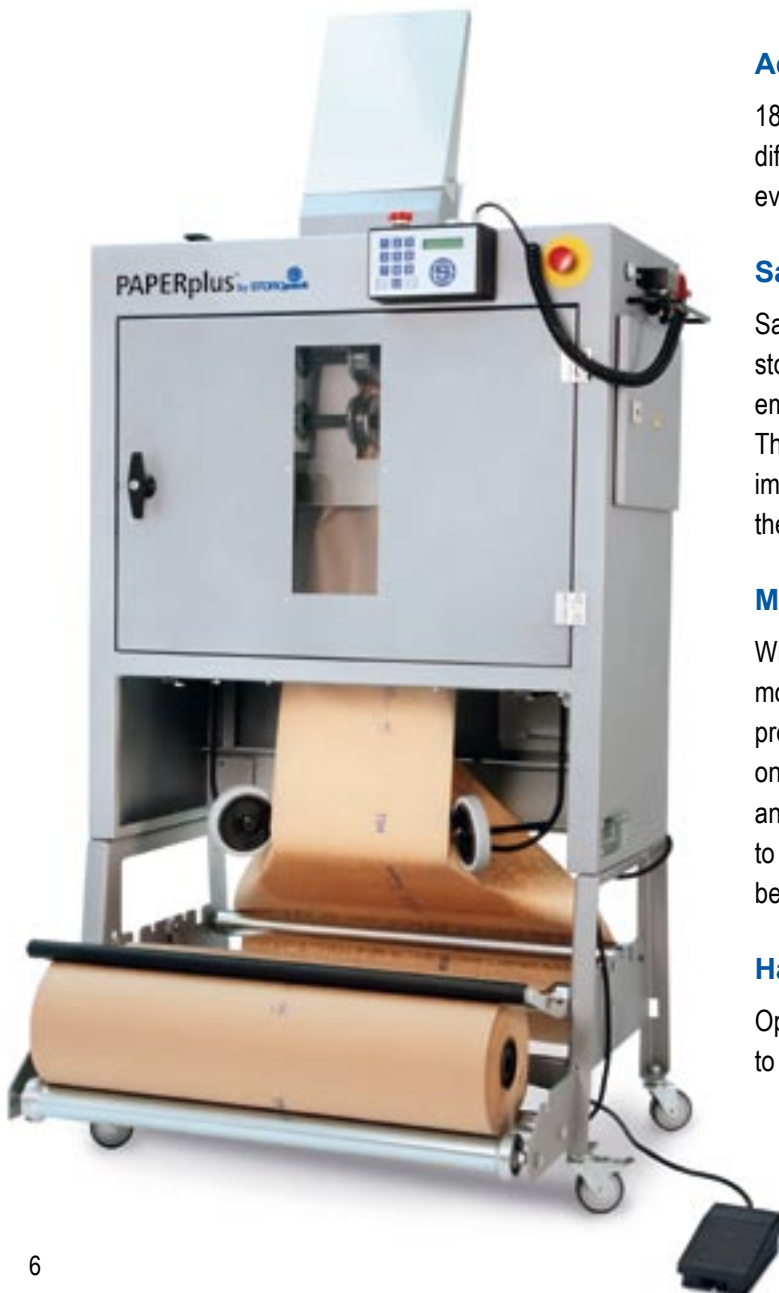

Adjustable and flexible:

180° directional chute lets you move and adjust to different operator height and work environments — even against a wall.

Safety:

Safety features include two easily accessible emergency stop buttons on each machine to ensure that your employees are always protected — just like your product. The machine is equipped with sensors that will detect immediately any malfunctions and stop the operation of the machine.

Mobility and control:

With nine modes of operation, the programmable and movable control pad gives operators full control of production, even from a distance. Produce pads on-demand or program production for multiple stations and/or multiple orders. This capability enables packers to be highly efficient, with minimal downtime. Units can be “locked-out” to simplify operators use.

Hands-free operation:

Operators are even more productive using the foot pedal to control output — leaving hands free for packing.

Two Classic Tabletop Models

The Classic Tabletop doubles the functionality by dispensing PAPERplus® pads directly to a tabletop packing station. Available in two sizes, the Classic Double Tabletop provides 75% more workspace than the single tabletop. Both come with adjustable table height capabilities.



Single Tabletop

Size:	33" H x 38" W x 62" D
Weight:	375 lbs
Power:	110 v
Speed:	42 fpm
Paper:	Single-, double-, or three-ply are standard



Double Tabletop

Size:	33" H x 55" W x 75" D
Weight:	430 lbs
Power:	110 v
Speed:	42 fpm
Paper:	Single-, double-, or three-ply are standard



Classic Horizontal

The Classic Horizontal extends over your packing station or packing line to conveniently and rapidly deliver PAPERplus® pads where you need them, when you need them.

Size:	70" H x 30" W x 60" D
Weight:	350 lbs
Power:	110 v
Speed:	Standard – 42 fpm High speed – 120 fpm
Paper:	Single-, double-, or three-ply are standard



PAPERplus[®] Chevron

Hybrid packaging tubes
combine air and paper to fill and protect

Functionality:

- ✓ Cushion
- ✓ Void-Fill
- ✓ Block & Brace



- Economical void-fill
- Light- to medium-weight cushioning
- Formed on-demand
- Reusable and recyclable

PAPERplus[®] Chevron is the smartest packing filler ever created. Using our patented pleating technique, Chevron combines paper and air to form a very lightweight and flexible 4" diameter tube that gives you maximum fill with less paper. You'll use fewer packing materials and your packages will be lighter, saving you money in two critical areas.



Creates a flexible paper and air cushion for light weight products.



Creates a true void-fill product by filling the void with air and paper.



Creates a paper pad to block and brace the product in the box.

Easy handling and versatility

Chevron's pleated paper tubes are flexible—making them easy to handle. They are perforated every 3" for easy separation allowing you to adjust the packing material length to fit your needs. In addition to economical void-fill, Chevron creates an effective cushioning material suitable to protect light- and medium-weight products of varying sizes.

Paper Specifications

Chevron offers multiple material options including different paper weights of standard brown kraft paper or white kraft paper popular for pharmaceutical and cosmetic applications. Both you and your customers will appreciate the reusable and recyclable aspects of Chevron.



Paper Type	Width x Length	Packaging Volume Per Roll
40#	8" x 1640'	132 ft ³
60#	8" x 1280'	124 ft ³

Fast, Efficient and Mobile

The PAPERplus® Chevron system can be integrated into any packaging process. Chevron is efficient, easy to load and operate, and extremely mobile, making it ideal for both high speed and individual packing station environments. Chevron paper tubes can be created on-demand, minimizing inventory and storage requirements, or produced in batches and fed into a Storopack bin.



Chevron

Footprint:	71" H x 35.5" W x 35.5" D
Weight:	397 lbs
Power:	110 v
Speed:	Standard - 66 fpm

Multi-Function Keyboard

The easy to use keypad has three programmable modes — manual, automatic and on-demand. This capability enables packers to be highly efficient, with minimal downtime by programming production for multiple stations and/or multiple orders, or producing Chevron tubes on-demand.



PAPERplus® Shooter

High-speed paper dispensing system

Functionality:

- ✓ Void-Fill
- ✓ Block & Brace



- Multi-layer void-fill using one-ply paper
- Speeds up production
- Easy set-up in special dispensing carton
- Neat, clean and recyclable

Need void-fill fast? With lightening speed of 220 - 550 FPM, the PAPERplus® Shooter mechanically creates multi-layer void-fill, automatically cuts the paper and “shoots” it directly into the box. The system increases productivity, saving time and reducing worker fatigue by replacing slow manual crumpling. In addition, enhanced crimping yields a bulkier paper cushion that maximizes one-ply paper to save on material costs.

As with all PAPERplus® packing products, our paper is made from virgin and recycled paper that is durable enough to be reused and is recyclable. The PAPERplus® Shooter offers a neat, clean and eco-friendly alternative for void-fill.



Makes an efficient void-fill and stabilizes the product.

Speed up your packing process

PAPERplus® Shooter creates a fast and effective void-fill product that works whether you’re packing single or multiple items. The paper is automatically crumpled and fed directly into the carton to speed up production.

Paper specifications

Paper Type	Width x Length	Rolls Per Skid
30#	14.75" x 2100'	36

In a specially designed carton the paper unwinds from the inside of the roll and feeds through the PAPERplus® Shooter, automatically creating multi-layer filler for on-demand availability. A seemingly simple design, the PAPERplus® Shooter is a well-constructed, high tech machine with features designed to improve your packing production including:

- Variable speed capability allows fit-for-purpose application and helps control cost
- Enhanced crimping system traps air to create better void-fill yield using less paper
- Automatic cutting and hands-free foot pedal operation provide better ergonomics and faster throughput
- On-demand option allows for cost-control in batch packaging applications
- Paper roll comes in specially designed dispensing carton for fast and easy roll changes
- Ergonomic height adjustment for operator benefit
- Tabletop or floor stand model adapt to any packing environment
- Free rotating head for packing flexibility



Tabletop Model Specifications

Size: 40" H x 18" W x 24" D
Weight: 39 lbs
Power: 115 V 60Hz
Speed: 220 - 550 fpm



Floor Model Specifications

Size: 69" H x 24" W x 24" D
Weight: 63 lbs
Power: 115 V 60Hz
Speed: 220 - 550 fpm



PAPERplus® Integrations

Integration at your service

PAPERplus® machines from Storopack provide the versatility that makes them easy to integrate into any packaging environment. With options such as single and double packing tables, vertical and horizontal machine designs, and tabletop or floor models, PAPERplus® offers maximum efficiencies for space and production capacity. We custom design and build ergonomic, innovative configurations depending on the application.

Storopack's Systems Integration Department works closely with you to develop a plan that provides the most efficient methods to deliver and use your packing materials. They carefully analyze your workflow, current process and facility. Their analysis includes consideration of details such as:

- **Improve productivity to reduce costs**
- **Speed and ease of supply material loading**
- **In-line or off-line packaging**
- **Pre-produced materials vs. on-demand production**
- **Ease of handling**
- **Maximum use of facility space**
- **Accessibility for loading and machine maintenance**
- **Environmental issues**
- **Optimized ergonomics and output**
- **Consideration of plans for future changes ...and more**

After a thorough analysis our engineers go to work to develop a proposal that effectively integrates the new machines into your existing facility or, if appropriate, a completely new layout of your packaging area. Our proposal is sent to you with drawings showing a clear picture of where and how the machines will be integrated into your facility so you'll be able to judge the added value of your investment. Once we receive your approval Storopack will deliver and install your new systems within 6 to 8 weeks.

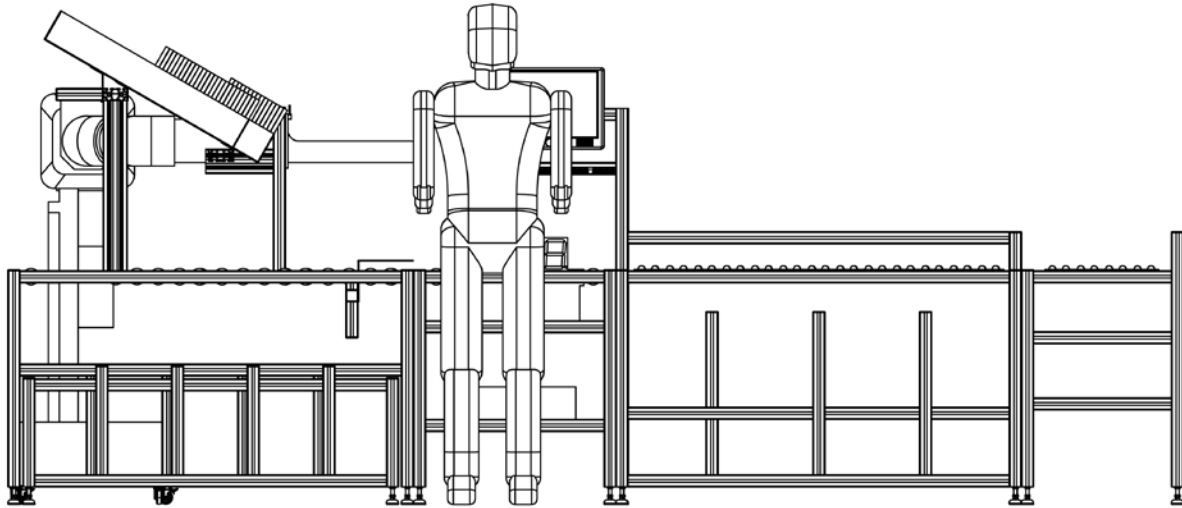

The first technical drawing of the packaging system integration.

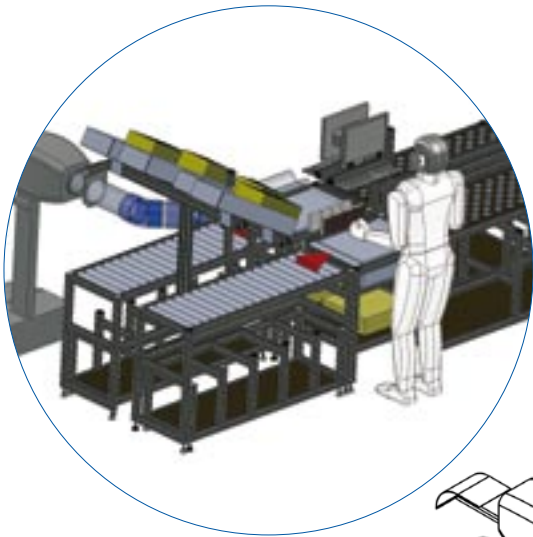

Example of a 3D drawing of a packaging system integration.

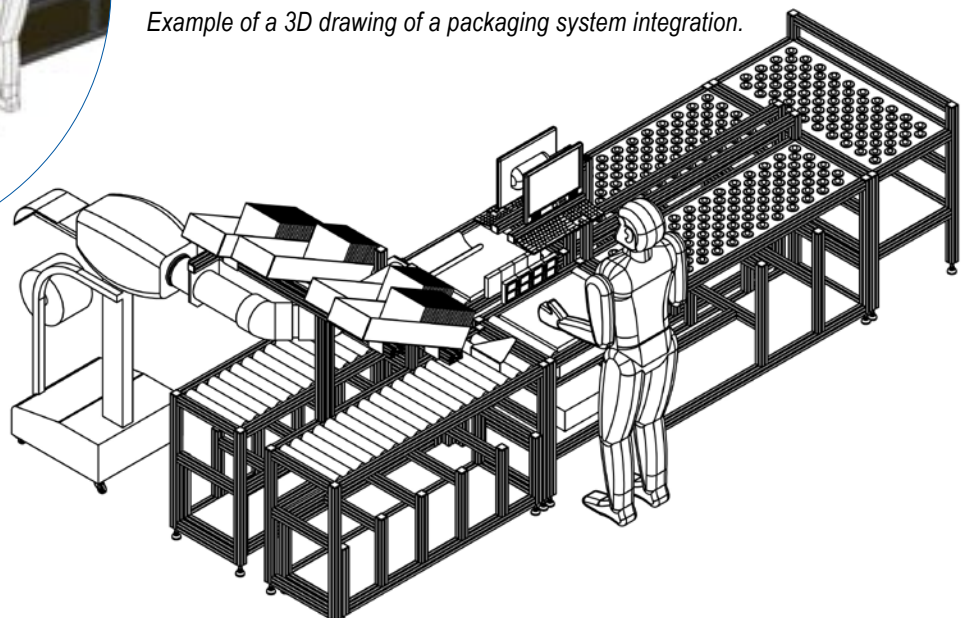



Integration at your service



Standard single packing table with PAPERplus® Classic under the table. Extras include AIRplus® Mini on a shelf, a carton rack, and a computer rack with TFT monitor connector.



A PAPERplus® Shooter mounted to a work station with a carton rack accessory above and a paper roll dispenser below.



AIRplus® Mini with Cushion film, and PAPERplus® Classic machine.

Modular and standard integration



Example of a PAPERplus® Classic tabletop machine integrated in a packaging line.



A Classic machine integrated in a pick-to-light book warehouse.



A Chevron machine on a packaging line.



In-line packaging using a Chevron machine.



A modified Shooter machine on a swivel puts the packaging material closer to the packer.

Expand your choices with Storopack's Single Source Triple Advantage!

At Storopack you'll find the product choices, availability, and reliable technology you need from one source. The power of Storopack's Triple Advantage makes it possible to create and coordinate workable solutions for positive outcomes with increased throughput, lower material cost and reduced damage.

- 1 Product:** Our broad range of packing materials and equipment give you access to solutions that satisfy every need from void-fill to protective cushioning for everything from fragile items to heavy industrial products.
- 2 Geography:** Storopack has more than 20 manufacturing facilities in North America and more than 70 combined locations worldwide for fast attentive service and efficient delivery of our products.
- 3 Technology:** Storopack is technology driven to develop cost-effective, efficient, and environmentally friendly products. Our equipment includes the newest technology for reliability, speed and ergonomics, and we provide the latest software and system upgrades.

More solutions from one source.

Packaging Products

PAPERplus® Cushioning Pads
PAPERplus® Shooter
PELASPAN-PAC® Loose-Fill
PELASPAN™ BIO Loose-Fill
AIRplus® Air Pillows
AIRplus® Cushion Film

AIRplus® Wave
AIRplus® Tube
PAD LOC® Moldable Pads
PAD LOC® BIO Moldable Pads
FOAMplus® Foam-In-Place

Individualized Services

Systems Integration
Consultation Services
Hybrid Packaging
Machine Customization
Product Imprinting
Retail Packaged Products

North American Headquarters Cincinnati

4758 Devitt Drive
Cincinnati, Ohio 45246
Phone: 1 513 874 0314
Fax: 1 513 874 2955

packaging.us@storopack.com
www.storopack.us

Atlanta

6140A Duquesne Drive
Atlanta, Georgia 30336
Phone: 1 404 344 6451
Fax: 1 404 344 4734

Cincinnati

4663 Dues Drive
Cincinnati, Ohio 45246
Phone: 1 513 860 1804
Fax: 1 513 860 4082

Cleveland

3135 Berea Road
Cleveland, Ohio 44111
Phone: 1 216 941 7225
Fax: 1 216 251 4744

Dallas

5050 Duncanville Road
Dallas, Texas 75236
Phone: 1 972 296 9535
Fax: 1 972 296 9843

Downey

12007 S. Woodruff Avenue
Downey, California 90241
Phone: 1 562 803 5582
Fax: 1 562 803 4462

Hillside

320 Craig Place
Hillside, Illinois 60162
Phone: 1 708 547 8030
Fax: 1 708 547 8096

Las Vegas

6140 North Hollywood Blvd.,
Suite 108
Las Vegas, Nevada 89115
Phone: 1 702 643 0070
Fax: 1 702 643 6008

Medley

11825 N.W. 100th Road, Suite 4
Medley, Florida 33178
Phone: 1 305 805 9696
Fax: 1 305 805 9697

Memphis

4290 Delp Street
Memphis, Tennessee 38118
Phone: 1 901 367 8053
Fax: 1 901 367 8055

Somerset

22 Worlds Fair Dr., Unit D
Somerset, New Jersey 08873
Phone: 1 732 560 1489
Fax: 1 732 560 1494

Phoenix

77 North 45th Avenue
Phoenix, Arizona 85043
Phone: 1 602 484 0831
Fax: 1 602 278 1011

Plymouth

13100 12th Ave., North
Plymouth, Minnesota 55441
Phone: 1 763 542 8351
Fax: 1 763 542 3147

San Jose

2210 Junction Avenue
San Jose, California 95131
Phone: 1 408 435 1537
Fax: 1 408 922 0316

Seattle

20418 87th Avenue South
Kent, Washington 98031
Phone: 1 253 872 6844
Fax: 1 253 872 5722

Tampa

4724 Transport Drive
Tampa, Florida 33605
Phone: 1 813 247 4226
Fax: 1 813 247 3677

Westboro

125 Flanders Road
Westboro, Massachusetts 01581
Phone: 1 508 366 1249
Fax: 1 508 366 9539

Winston-Salem

2598 G Empire Drive
Winston-Salem, NC 27103
Phone: 1 336 765 7767
Fax: 1 336 760 4426

Canada:

Montreal

57 Hymus Blvd
Pointe Claire, Quebec
H9R 4T2
Phone: 1 (514) 426 7192
Fax: 1 (514) 694 7405

Toronto

10 Woodslea Road Unit 2
Brampton, Ontario L6T 5P2
Phone: 1 (905) 792 9567
Fax: 1 (905) 792 8737

For all other countries:

Asia

Phone: +852 3421 2392
Fax: +852 3421 2720
packaging.asia@storopack.com
www.storopack.hk

Europe

Phone: +49 (0)7123 164-0
Fax: +49 (0)7123 164-119
packaging@storopack.com
www.storopack.com



STOROpack