

# FOAMplus<sup>®</sup> by STOROpack



**STOROpack**

# Custom made packaging for



Product overview	3
FOAMplus® Bagpacker	4
FOAMplus® Handpacker	6
Accessories	8
System integrations	10



# your products

## FOAMplus<sup>®</sup> by STOROpack

FOAMplus<sup>®</sup> from Storopack is a unique packaging solution that forms a perfect fit around any product regardless of size, weight or fragility. The FOAMplus<sup>®</sup> molded cushions are produced on demand at the packing station and form to the shape of the product. The cushion is extremely impact-resistant and lightweight, providing a high-grade, custom-fit protective barrier for your product.

### Safe and sound protection

- FOAMplus<sup>®</sup> ensures that your customer receives an undamaged product in clean, professional packaging.
- FOAMplus<sup>®</sup> adapts perfectly: Whether you use the hand-held or foam-filled bag system, you can always be confident that FOAMplus<sup>®</sup> will mold around the product, protecting it like a glove.
- FOAMplus<sup>®</sup> is versatile: A wide selection of foam densities allows you to use FOAMplus to package any type of product.
- FOAMplus<sup>®</sup> offers outstanding protection: The foam sets to an impact-resistant cushion, holding the product securely and keeping it safe.
- FOAMplus<sup>®</sup> saves space: Foam cushions are produced as needed and the systems are extremely compact, giving you maximum yield while using minimal space. A unit with two 55 gallon drums can produce up to 3,200 cubic feet of protective foam cushioning.
- FOAMplus<sup>®</sup> keeps transportation costs down: FOAMplus<sup>®</sup> provides superior protection and is very light weight.

### Watch for this functionality key

This convenient guide is shown throughout our catalog to help you choose the right FOAMplus<sup>®</sup> product. The functions highlighted on the side of the box ensure you're getting the product that will meet your packaging needs.

#### Cushion:

Absorbs shock. Protects products.

#### Block and Brace:

Holds heavy items or single objects in place inside the box.

#### Void-fill:

Fills empty space and keeps products from rattling in the box.

#### Wrap:

Covers product surfaces to avoid contact damage and provides all sides with shock protection.



# FOAMplus® Bagpacker

## The foam-in-bag system

### Functionality:

- ✓ Cushion
- ✓ Void-Fill
- ✓ Block & Brace



- Easy to use
- Self-cleaning gun
- Minimum maintenance
- Multiple bag sizes and fill settings

The FOAMplus® Bagpacker is fast, easy, efficient and economical, making it the first choice in foam-in-bag systems. The machine can produce up to 23 foam-filled bags per minute at the touch of a button. FOAMplus® bags save time and money while providing secure protection for products of virtually any size, shape or weight. The controller has a built-in programmable timer designed to cut waste and simplify operator training. A self-cleaning gun and robust machine design help to keep maintenance costs to a minimum. In addition, the stand adjusts easily to varying heights to ensure operator comfort.



### Bagpacker

<b>Size:</b>	59" x 79" x 29.5"
<b>Weight:</b>	770 lbs
<b>Power:</b>	220 V - 30 amps
<b>Speed:</b>	23 bags per minute

### Practical and simple: The controls

The FOAMplus® Bagpacker controller is simple to operate and offers maximum flexibility. Easily program and store up to 594 settings for varying bag sizes and foam-fill amounts.

# Safe, quick, simple: the application

## Individual solution

1 Using a pre-programmed keypad setting, a precisely metered volume of foam is dispensed into the liner. The liner is then heat-sealed along the pre-set length to form a bag.



2 The bag is immediately placed in the box, and the product lowered in as the foam continues to expand.



3 A second pre-filled bag is placed on top.



4 A few seconds later the FOAMplus® foam has set, forming a clean protective barrier that fits neatly around the product.



## Pre-forming

1 Using a pre-programmed keypad setting, a carefully metered volume of foam is dispensed into the liner. The liner is then heat-sealed along the pre-set length to form a bag.



2 The bag containing FOAMplus® is placed in a mold designed to match the product.



3 The lid is closed. The FOAMplus® foam expands inside the box and only a few seconds later it has set.



4 The made-to-measure packaging is ready and waiting. FOAMplus® provides customized protective packaging without the storage.



# FOAMplus® Handpacker

## The direct-foam system

### Functionality:

- ✓ Cushion
- ✓ Void-Fill
- ✓ Block & Brace



- Microprocessor control
- Self-diagnosing software
- Self-cleaning gun
- Controlled dispensing

The FOAMplus® Handpacker is manually operated, with a fully electronic microprocessor control to maintain consistent quality. Its performance capability makes FOAMplus® one of the fastest foam-packaging systems—speeding up the packing process without sacrificing packaging quality.

The self-diagnosing software in the FOAMplus® system keeps everything working smoothly and effectively. The foam gun is self-cleaning and delivers packaging foam of the very highest quality.



### Handpacker

**Size:** 29" x 56" x 16"

**Weight:** 375 lbs

**Power:** 220 V - 30 amps

### Practical and simple: The controls

The FOAMplus® Handpacker controller is easy to program and use. Preset timer-controlled dispensing makes operation efficient, and minimizes mistakes and material waste.

# Simplicity plus dependability: The applications

## Individual solution

1 Once the FOAMplus® liner has been spread in the container, the FOAMplus® foam is dispensed directly into the box and the liner is folded over the expanded foam.



2 The product you want protected is placed onto the foam while it continues to expand.



3 A second liner protects the product and the top cushion of foam is dispensed.



4 FOAMplus® molds itself around the product, providing optimum protection against damage in transit.



## Pre-forming

1 Storopack can design simple wooden molds, which are perfect for manufacturing tailor-fit packaging for batch products.



2 A vacuum draws the FOAMplus® liner into every contour of the mold and a preset amount of foam is dispensed. The lid is closed and the foam expands inside the mold.



3 FOAMplus® needs only a few seconds to set. Then the pre-shaped cushion can be lifted out and placed in its box, ready for the product.



4 It's the quick, easy and cost-effective way to produce batch after batch of custom protective packaging.



# FOAMplus® Accessories

Practical and efficient



## The Foam Components.

Two liquid components (Component A, a mineral oil-based diphenylmethane di-isocyanate, and Component B, a saponified polyol mixture) react together to form a (H)CFC-free polyurethane packaging foam, which expands up to 280 times its original volume within 15 to 25 seconds, depending on the foam thickness.

## The Film.

The FOAMplus® film, available in standard and antistatic quality, is specifically developed for the FOAMplus® system. It combines tremendous strength with flexibility, and acts as a cushioning envelope. The film comes in rolls and is available in a range of widths to suit the application. Each roll carries the environmental-protection data you require, along with our free hotline number to dial if you want additional information.



## The Gun.

The FOAMplus® gun has a self-cleaning mixing chamber. The revolutionary system combines the gun and controller to ensure outstanding reliability. Accurate metering, versatility, high efficiency and reduced maintenance costs make FOAMplus® best-in-class.

## FOAMplus® accessories

Storopack provides a range of accessories for FOAMplus® systems including a manual cutting system for liner rolls up to 48" wide, and packing tables. In addition, FOAMplus® can be integrated seamlessly into production lines and with other Storopack packaging systems.



## Made-to-measure packaging: Quality and ease of use.

FOAMplus® makes it easy to produce your own custom packaging on-demand. The molding system is easy to use and can produce as many as 13 cushions per minute. As they are formed, the FOAMplus® cushions can simply be placed directly into the packaging carton around the product and the package is ready to go. On-demand custom packaging molds save valuable time and costly storage space.

## FOAMplus® Backpacker in combination with the Dual-Station



*Backpacker machine in combination with the FOAMplus® Dual-Station.*



*Step 1: The operator chooses a pre-programmed bag setting.*



*Step 2: The operator places the foam-filled bag in the wooden mold.*



*Step 3: The mold is closed to allow the foam to expand inside.*



*Step 4: After a few seconds the FOAMplus® cushion is ready.*



*With the FOAMplus® Dual-Station you can quickly make protective cushions for a variety of products.*

# FOAMplus® Integration

## Integration at your service

FOAMplus® machines from Storopack integrate easily into any packing environment. Their speed makes them an efficient and convenient in-line packing tool. The small footprint offers maximum efficiencies for space and production capacity.

Storopack's Systems Integration Department works closely with you to develop a plan that provides the most efficient methods to deliver and use your packing materials. First they carefully analyze your workflow, current process and facility. Their analysis includes consideration of details such as:

- **In-line or off-line packaging**
- **Pre-produced materials vs. on-demand production**
- **Ease of handling**
- **Speed and ease of supply material loading**
- **Maximum use of facility space**
- **Accessibility for loading and machine maintenance**
- **Environmental issues**
- **Optimized ergonomics and output**
- **Consideration of plans for future changes ...and more**

After a thorough analysis our engineers go to work to develop a proposal that effectively integrates the new machines into your existing facility or, if appropriate, a completely new layout of your packaging area. Our proposal is sent to you with drawings showing a clear picture of where and how the machines will be integrated into your facility so you'll be able to judge the added value of your investment. Once we receive your approval Storopack will deliver and install your new systems within 6 to 8 weeks.

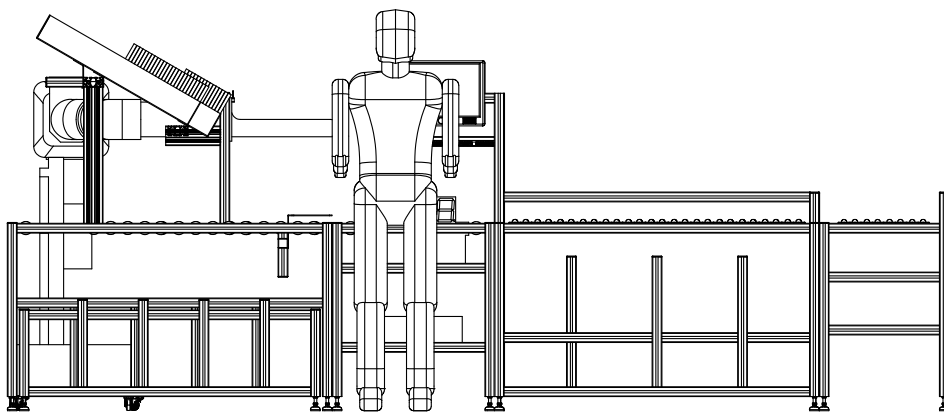

*The first technical drawing of the packaging system integration.*

## Integration at the packing table



*FOAMplus® Bagpacker machine with a single packing table solution.*

## Modular integration



*Multiple FOAMplus® Bagpacker machines integrated in a direct conveyor technique.*

# Expand your choices with Storopack's Single Source Triple Advantage!

At Storopack you'll find the product choices, availability, and reliable technology you need from one source. The power of Storopack's Triple Advantage makes it possible to create and coordinate workable solutions for positive outcomes with increased throughput, lower material cost and reduced damage.

- 1 Product:** Our broad range of packing materials and equipment give you access to solutions that satisfy every need from void-fill to protective cushioning for everything from fragile items to heavy industrial products.
- 2 Geography:** Storopack has more than 20 manufacturing facilities in North America and more than 70 combined locations worldwide for fast attentive service and efficient delivery of our products.
- 3 Technology:** Storopack is technology driven to develop cost-effective, efficient, and environmentally friendly products. Our equipment includes the newest technology for reliability, speed and ergonomics, and we provide the latest software and system upgrades.

More solutions from one source.

## Packaging Products

PAPERplus® Cushioning Pads  
PAPERplus® Shooter  
PELASPAN-PAC® Loose-Fill  
PELASPAN™ BIO Loose-Fill  
AIRplus® Air Pillows  
AIRplus® Cushion Film

AIRplus® Wave  
AIRplus® Tube  
PAD LOC® Moldable Pads  
PAD LOC® BIO Moldable Pads  
FOAMplus® Foam-In-Place

## Individualized Services

Systems Integration  
Consultation Services  
Hybrid Packaging  
Machine Customization  
Product Imprinting  
Retail Packaged Products

## North American Headquarters Cincinnati

4758 Devitt Drive  
Cincinnati, Ohio 45246  
Phone: 1 513 874 0314  
Fax: 1 513 874 2955

packaging.us@storopack.com  
www.storopack.us

## Atlanta

6140A Duquesne Drive  
Atlanta, Georgia 30336  
Phone: 1 404 344 6451  
Fax: 1 404 344 4734

## Cincinnati

4663 Dues Drive  
Cincinnati, Ohio 45246  
Phone: 1 513 860 1804  
Fax: 1 513 860 4082

## Cleveland

3135 Berea Road  
Cleveland, Ohio 44111  
Phone: 1 216 941 7225  
Fax: 1 216 251 4744

## Dallas

5050 Duncanville Road  
Dallas, Texas 75236  
Phone: 1 972 296 9535  
Fax: 1 972 296 9843

## Downey

12007 S. Woodruff Avenue  
Downey, California 90241  
Phone: 1 562 803 5582  
Fax: 1 562 803 4462

## Hillside

320 Craig Place  
Hillside, Illinois 60162  
Phone: 1 708 547 8030  
Fax: 1 708 547 8096

## Las Vegas

6140 North Hollywood Blvd.,  
Suite 108  
Las Vegas, Nevada 89115  
Phone: 1 702 643 0070  
Fax: 1 702 643 6008

## Medley

11825 N.W. 100th Road, Suite 4  
Medley, Florida 33178  
Phone: 1 305 805 9696  
Fax: 1 305 805 9697

## Memphis

4290 Delp Street  
Memphis, Tennessee 38118  
Phone: 1 901 367 8053  
Fax: 1 901 367 8055

## Somerset

22 Worlds Fair Dr., Unit D  
Somerset, New Jersey 08873  
Phone: 1 732 560 1489  
Fax: 1 732 560 1494

## Phoenix

77 North 45th Avenue  
Phoenix, Arizona 85043  
Phone: 1 602 484 0831  
Fax: 1 602 278 1011

## Plymouth

13100 12th Ave., North  
Plymouth, Minnesota 55441  
Phone: 1 763 542 8351  
Fax: 1 763 542 3147

## San Jose

2210 Junction Avenue  
San Jose, California 95131  
Phone: 1 408 435 1537  
Fax: 1 408 922 0316

## Seattle

20418 87th Avenue South  
Kent, Washington 98031  
Phone: 1 253 872 6844  
Fax: 1 253 872 5722

## Tampa

4724 Transport Drive  
Tampa, Florida 33605  
Phone: 1 813 247 4226  
Fax: 1 813 247 3677

## Westboro

125 Flanders Road  
Westboro, Massachusetts  
01581  
Phone: 1 508 366 1249  
Fax: 1 508 366 9539

## Winston-Salem

2598 G Empire Drive  
Winston-Salem, NC 27103  
Phone: 1 336 765 7767  
Fax: 1 336 760 4426

## Canada:

### Montreal

57 Hymus Blvd  
Pointe Claire, Quebec  
H9R 4T2  
Phone: 1 (514) 426 7192  
Fax: 1 (514) 694 7405

### Toronto

10 Woodslea Road Unit 2  
Brampton, Ontario L6T 5P2  
Phone: 1 (905) 792 9567  
Fax: 1 (905) 792 8737

## For all other countries:

### Asia

Phone: +852 3421 2392  
Fax: +852 3421 2720  
packaging.asia@storopack.com  
www.storopack.hk

### Europe

Phone: +49 (0)7123 164-0  
Fax: +49 (0)7123 164-119  
packaging@storopack.com  
www.storopack.com

